

# SHURflo<sup>®</sup> Marine Grade Faucets

## INSTALLATION INSTRUCTIONS

### OEM Version

**Attention Manufacturers:**  
Please include this Installation  
Instruction sheet with your Owner's  
Documentation.

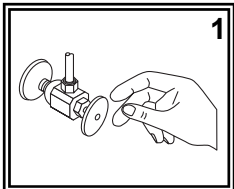

- (1) Turn off the water supply to your existing faucet (this procedure will vary depending on the specific plumbing system installed on your boat). Cover the sink drain to prevent any small parts or debris from falling in. Remove your existing faucet, taking care not to damage your existing water lines. Clean sink area in preparation for new faucet.

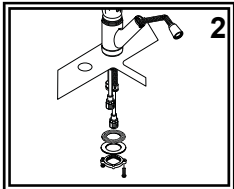

- (2) Place the faucet in the center hole of the sink. Pull the flex hose all the way up until the hose stops. Slide the black rubber washer and then the metal washer onto the mounting shaft. Screw the brass lock nut on mounting shaft with the two screws pointing up, as illustrated. Hand tighten the brass lock nut. Position the faucet on the sink and tighten the lock nut screws with a screwdriver. CAUTION: DO NOT OVER TIGHTEN THE SCREWS.

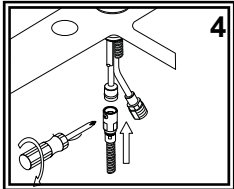

- (3) Very gently bend the copper water inlet tubes slightly out, to allow for larger hose clearance. CAUTION: USE CARE WHEN BENDING THE TUBES. Grip at point of bend with one hand and adjust with the other.

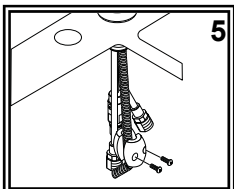

- (4) Screw the pipe adapter onto the flex hose. Use Teflon tape on threads. Hold the hose tightly while turning the adapter. Do not allow hose to twist as it may kink. Push the pipe adapter onto the third copper pipe with the male fitting, until you feel it "snap" into place. You may need to slightly rotate the adapter side to side while pushing it on. Tighten the pipe adapter screw to secure. The pipe adapter screw should screw completely in. Pipe adapter may rotate after connection is secure. Ensure water supply lines do not interfere with flex hose.

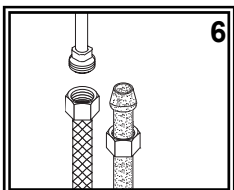

- (5) Attach metal weight to hose. Adjust position as desired. Weight must be installed to prevent hose kinking and for easy hose return.

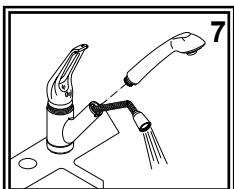

- (6) Connect water supply lines (not provided) to the connector hoses. Wrap the brass fittings on the connector hoses with Teflon (Plumber's) tape. Follow the appropriate steps depending on your water supply lines. If you have pre-assembled water supply hoses with threaded connectors, simply screw on supply hose. If you have plastic water lines with formed ends, water lines will seat partially up into the brass fittings. Connect by tightening the coupling nuts. We do NOT suggest using sweat fittings as they are prone to blow-outs.

- (7) Unscrew the spout head from the flex hose. Turn the water supplies back on and allow both hot and cold water to run for at least one full minute. While water is running, check all connections for leaks. Replace the spout head. Connections may need re-tightening

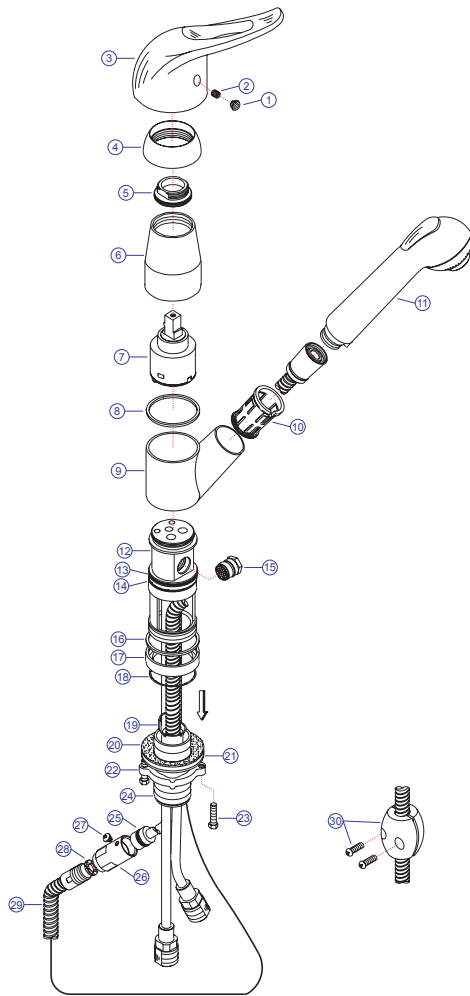

### Parts

- 1) Blue/Red Cap
- 2) Handle Screw
- 3) Handle
- 4) Cap
- 5) Retainer Ring
- 6) Cover
- 7) Ceramic Disc Cartridge
- 8) Packing Ring
- 9) Spout Hub
- 10) Hose Nest
- 11) Spout Head
- 12) Valve Body
- 13) O-Ring
- 14) O-Ring
- 15) Internal Vacuum Breaker
- 16) Packing Ring
- 17) Base Ring
- 18) Gasket
- 19) Hose Guide
- 20) Rubber Washer
- 21) Metal Washer
- 22) Lock Nut
- 23) Lock Nut Screws
- 24) Mounting Shaft
- 25) Pipe Adaptor O-Ring
- 26) Pipe Adaptor
- 27) Pipe Adaptor Screw
- 28) Pipe Adapter Washer
- 29) Flex Hose
- 30) Weight & Screws

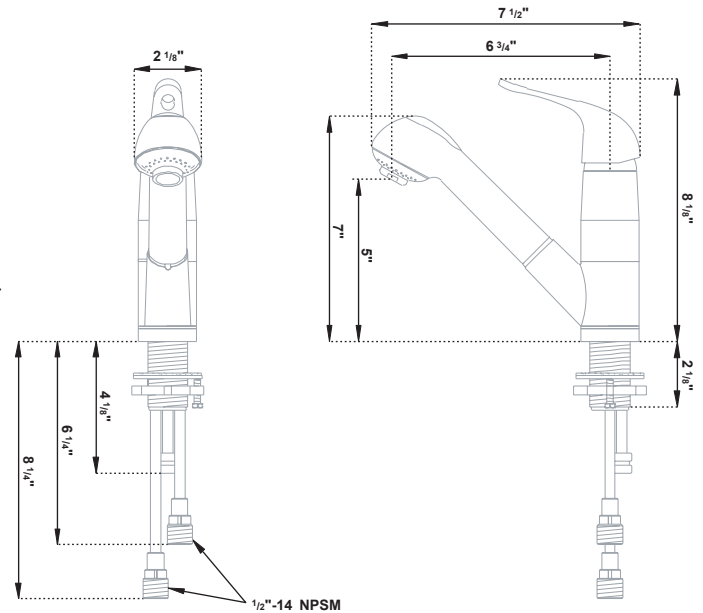

### PROPER FINISH CARE:

Your new faucet is protected by a clear-coat. To clean it, you only need to wipe it with a damp, soft cloth. NEVER use any abrasive cleaners, steel wool, or chemicals, as they will harm the finish and void your warranty. If the faucet will be installed in a salt-air environment (boat exterior), regular cleaning with gentle soap and carnauba wax will prolong the life of the finish.

### LIMITED WARRANTY

SHURflo Marine Grade Faucets & Accessories are guaranteed to be free from material and workmanship defects under normal use and service for a period of three (3) years from the date of manufactured vessel for all indoor applications and two (2) years from the date of manufactured vessel for all outdoor applications. This limited warranty will not apply to faucets or accessories that were improperly installed, misapplied, or incompatible with components not manufactured by SHURflo. Faucet failure due to foreign debris is not covered under the terms of this limited warranty. SHURflo will not warrant any faucet that is physically damaged, or altered outside the SHURflo factory. Warranty claims may be resolved by a SHURflo service center. All returns are to be shipped with charges pre-paid. Package all returns carefully. SHURflo will not be responsible for freight damage incurred during shipping to a service center. SHURflo's obligation under this warranty policy is limited to the repair or replacement of the faucets & accessories. Faucets or accessories found not defective (under the terms of this limited warranty) are subject to charges to be paid by the returnee for the testing and packaging of "tested good" units. Warranty returns will be shipped on a freight allowed basis. SHURflo reserves the right to choose the method of transportation. SHURflo is not responsible nor will it reimburse for labor necessary to remove and reinstall a faucet or accessory, if found defective. This warranty is only a representation of the complete Marine Products Limited Warranty outlined by Service Bulletin #1050.

★ SHURflo reserves the right to update specifications, prices, or make substitutions.



**SHURflo\***  
5900-A Katella Ave.  
Cypress, CA 90630  
(562) 795-5200 (800) 854-3218  
FAX (562) 795-7564  
**Shipping:** 5900-C Katella Ave.  
Cypress, CA 90630

**SHURflo East**  
52748 Park Six Court  
Elkhart, IN 46514-5427  
(574) 262-0478 (800) 762-8094  
FAX (574) 264-2169  
<http://www.shurflo.com>

**SHURflo Ltd.\***  
Unit 5 Sterling Park  
Gatwick Road, Crawley  
West Sussex, RH10 2QT  
United Kingdom  
+44 1293 424000  
FAX +44 1293 421880

