

| Rev. Change | |
|-------------|----------|
| A | Original |
| B | |
| C | |
| D | |

V03-0716-xx

formerly Ambassador Marine
 5900 Katella Ave., Cypress, CA 90630
 800.854.3218 • 562.795.5200 • Fax 562.795.7564
 www.shurflo.com



| | | | | | |
|------------|----------------------------|-------------------|-----------------|------------|-------------------------------|
| Stopper | Touch | Package Style | Poly Bag | Model # | V03-0716-xx |
| Connection | 1 1/4" -M Thread | Drain Series | Trap Sink Drain | Drain Type | Touch Trap Drain (With Cover) |
| Drain Size | 1 3/4" (Fits: 1 7/8" Hole) | Modified/Approved | SS - 9/23/08 | | |

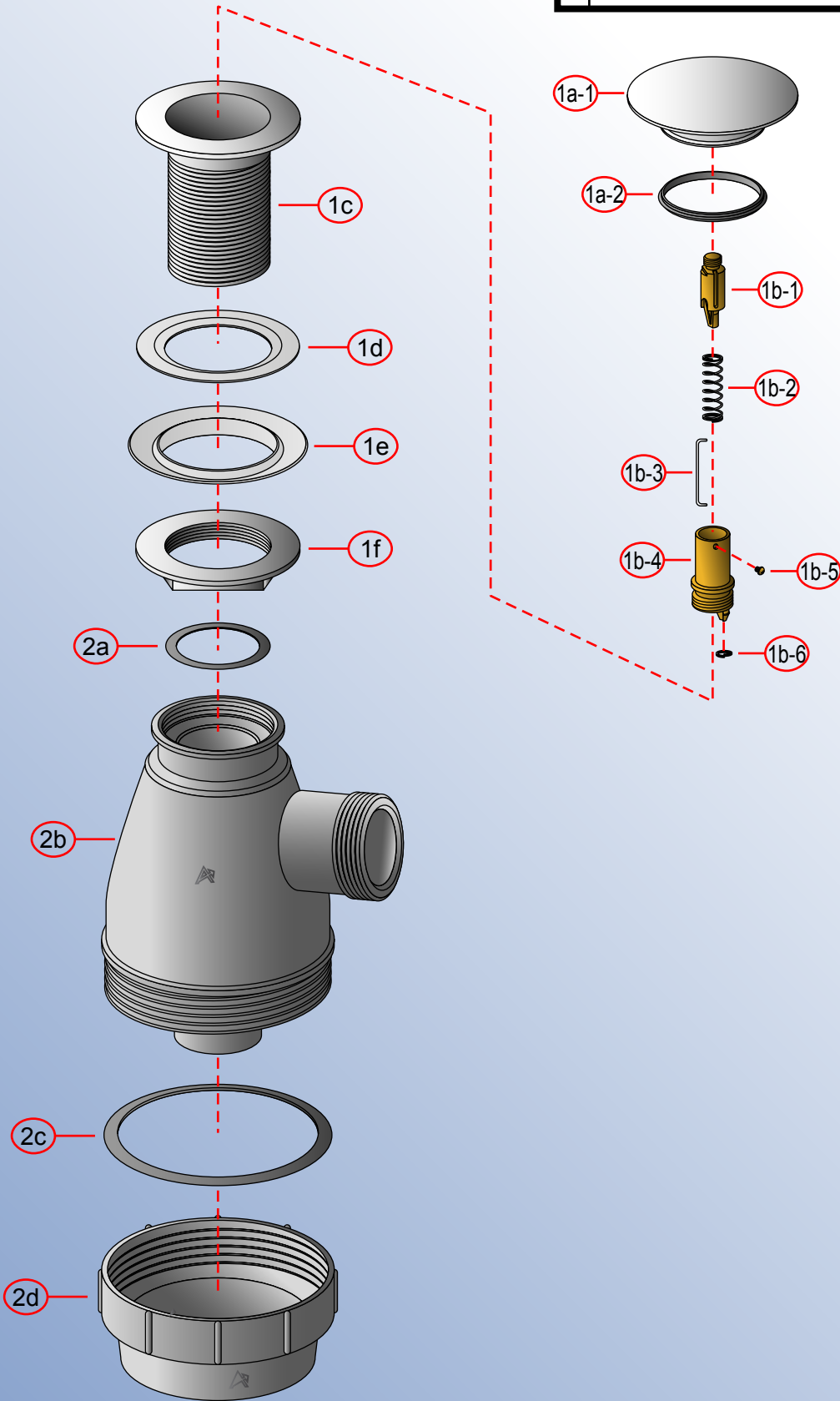

NOT DRAWN TO SCALE

